

Rozšířená nabídka držáků a planžet řady T-CLAMP ULTRA PLUS

■ Planžety pro čelní obrábění
typ TGBFR/L ...

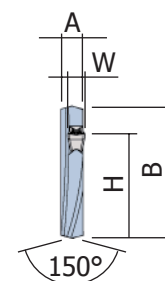

Větší rozsah průměrů

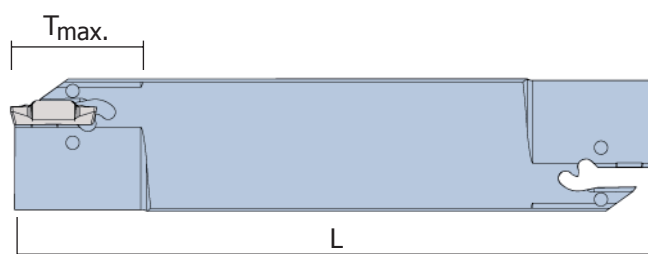

objedn. číslo	W	B	L	H	A	T _{max.}	D _{min.}	D _{max.}	upnutí	
TGBFR/L 32T20-40-60-3	3	32	150	24,8	5,2	20	40	60	klíč EDG-33B	
TGBFR/L 32T20-54-80-3	3	32	150	24,8	5,2	20	54	80		
TGBFR/L 32T25-74-120-3	3	32	150	24,8	5,2	25	74	120		
TGBFR/L 32T25-114-180-3	3	32	150	24,8	5,2	25	114	180		
TGBFR/L 32T25-40-60-4	4	32	150	24,8	5,2	25	40	60		
TGBFR/L 32T25-50-80-4	4	32	150	24,8	5,2	25	50	80		
TGBFR/L 32T30-70-130-4	4	32	150	24,8	5,2	30	70	130		
TGBFR/L 32T30-120-200-4	4	32	150	24,8	5,2	30	120	200		
TGBFR/L 32T32-60-95-5	5	32	150	24,8	5,2	32	60	95		držák TTBN... - 32 TTBU... - 32
TGBFR/L 32T35-85-140-5	5	32	150	24,8	5,2	35	85	140		
TGBFR/L 32T35-130-250-5	5	32	150	24,8	5,2	35	130	250		
TGBFR/L 32T32-80-180-6	6	32	150	24,8	5,2	32	80	180		
TGBFR/L 32T38-168-300-6	6	32	150	24,8	5,2	38	168	300		
TGBFR/L 32T30-200-4	4	32	150	24,9	5,2	30	200	∞		
TGBFR/L 32T35-250-5	5	32	150	24,9	5,2	35	250	∞		
TGBFR/L 32T38-300-6	6	32	150	24,9	5,2	38	300	∞		

■ Integrální držáky pro čelní obrábění
typ TTFR/L ...



Větší rozsah
průměrů

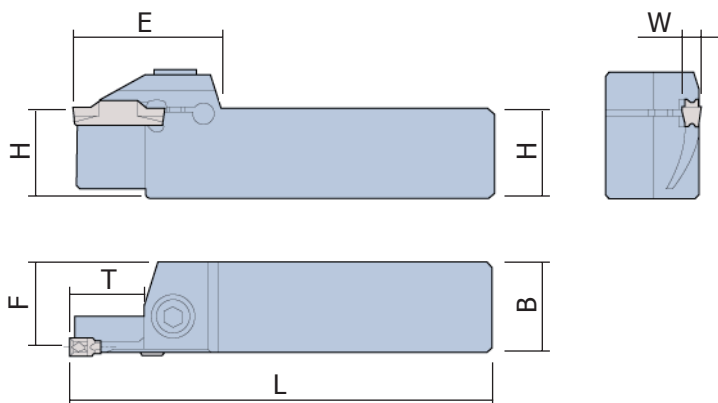

objedn. číslo	W	H	B	L	F	E	T _{max.}	D _{min.}	D _{max.}	upnutí
TTFR/L 25-30-3	3	25	25	150	24,0	32	10	24	35	šroub SH M5x0,8x25 klíč L-W 4 M = 5,5 Nm
TTFR/L 25-35-3	3	25	25	150	24,0	32	10	29	40	
TTFR/L 25-40-3	3	25	25	150	24,0	32	10	34	50	
TTFR/L 25-50-3	3	25	25	150	24,0	32	15	44	60	
TTFR/L 25-60-3	3	25	25	150	24,0	32	15	54	85	
TTFR/L 25-30-4	4	25	25	150	23,6	33	12	22	40	šroub SH M6x1x25 klíč L-W 5 M = 8,0 Nm
TTFR/L 25-40-4	4	25	25	150	23,6	33	15	32	50	
TTFR/L 25-50-4	4	25	25	150	23,6	33	15	42	60	
TTFR/L 25-60-4	4	25	25	150	23,6	33	15	52	85	
TTFR/L 25-60-6	6	25	25	150	22,6	37	20	48	85	
TTFR/L 25-85-6	6	25	25	150	22,6	37	20	73	150	
TTFR/L 25-150-6	6	25	25	150	22,6	37	20	138	250	
TTFR/L 25-250-6	5	25	25	150	22,6	37	20	250	∞	

■ Integrovaný držák pro čelní obrábění typ TTFR/L ... RN



Větší rozsah
průměrů

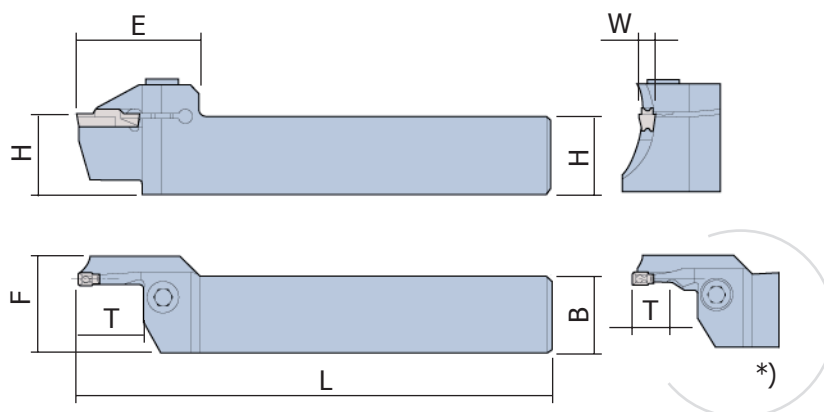

objedn. číslo	W	H	B	L	F	E	T _{max.}	D _{max.}	D _{min.}	upnutí
TTFR/L 25-30-3 RN *)	3	25	25	150	24,0	38	10	24	35	šroub SH M6x1x25 klíč L-W 5 M = 8,0 Nm 1
TTFR/L 25-35-3 RN *)	3	25	25	150	24,0	38	10	29	40	
TTFR/L 25-40-3 RN *)	3	25	25	150	24,0	38	10	34	50	
TTFR/L 25-50-3 RN	3	25	25	150	24,0	38	15	44	70	
TTFR/L 25-70-3 RN	3	25	25	150	24,0	38	15	64	100	
TTFR/L 25-30-4 RN *)	4	25	25	150	23,6	39	10	22	36	
TTFR/L 25-36-4 RN	4	25	25	150	23,6	39	20	28	42	
TTFR/L 25-42-4 RN	4	25	25	150	23,6	39	20	34	50	
TTFR/L 25-50-4 RN	4	25	25	150	23,6	39	20	42	70	
TTFR/L 25-70-4 RN	4	25	25	150	23,6	39	20	62	120	
TTFR/L 25-120-4 RN	4	25	25	150	23,6	39	20	112	200	
TTFR/L 25-60-5 RN	5	25	25	150	23,1	49	25	50	80	šroub SH M8x1,25x25 klíč L-W 6 M= 12,0 Nm 2
TTFR/L 25-80-5 RN	5	25	25	150	23,1	49	25	70	110	
TTFR/L 25-110-5 RN	5	25	25	150	23,1	49	25	100	150	
TTFR/L 25-150-5 RN	5	25	25	150	23,1	49	25	140	200	
TTFR/L 25-60-6 RN	6	25	25	150	22,6	49	25	48	70	
TTFR/L 25-70-6 RN	6	25	25	150	22,6	49	25	58	100	
TTFR/L 25-100-6 RN	6	25	25	150	22,6	49	25	88	180	
TTFR/L 25-180-6 RN	6	25	25	150	22,6	49	25	168	400	
TTFR/L 25-200-4 RN	4	25	25	150	23,6	39	20	200	∞	
TTFR/L 25-200-5 RN	5	25	25	150	23,1	49	25	200	∞	
TTFR/L 25-400-6 RN	6	25	25	150	22,6	49	25	400	∞	

■ Integrovaní držáky pro čelní obrábění

typ TTFPR/L ... RN



Větší rozsah
průměrů

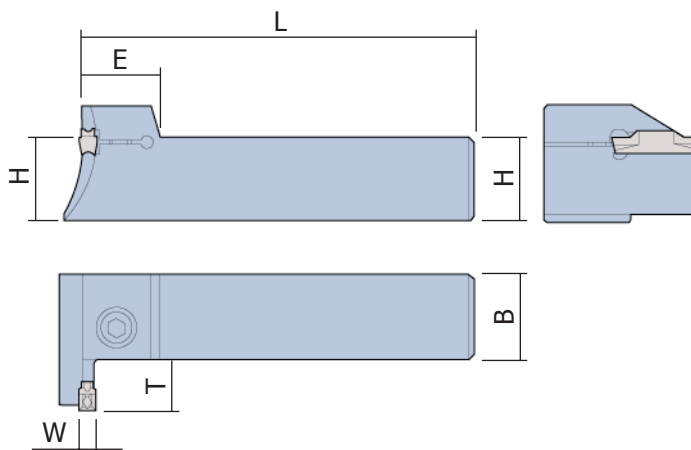

objedn. číslo	W	H	B	L	E	T _{max.}	D _{min.}	D _{max.}	upnutí
TTFPR/L 25-30-3	3	25	25	150	18	10	24	35	šroub SH M5x0,8x25 klíč L-W 4 M = 5,5 Nm
TTFPR/L 25-35-3	3	25	25	150	18	10	29	40	
TTFPR/L 25-40-3	3	25	25	150	18	10	34	50	
TTFPR/L 25-50-3	3	25	25	150	18	15	44	60	
TTFPR/L 25-60-3	3	25	25	150	18	15	54	85	
TTFPR/L 25-30-4	4	25	25	150	18,5	12	22	40	šroub SH M6x1x25 klíč L-W 5 M = 8,0 Nm
TTFPR/L 25-40-4	4	25	25	150	18,5	15	32	50	
TTFPR/L 25-50-4	4	25	25	150	18,5	15	42	60	
TTFPR/L 25-60-4	4	25	25	150	18,5	15	52	85	
TTFPR/L 25-60-5	5	25	25	150	22	20	50	80	šroub SH M8x1,25x25 klíč L-W 6 M = 12,0 Nm
TTFPR/L 25-80-5	5	25	25	150	22	20	70	110	
TTFPR/L 25-110-5	5	25	25	150	22	20	100	150	
TTFPR/L 25-150-5	5	25	25	150	22	20	140	200	
TTFPR/L 25-60-6	6	25	25	150	22	20	48	85	
TTFPR/L 25-85-6	6	25	25	150	22	20	73	150	
TTFPR/L 25-150-6	6	25	25	150	22	20	138	250	M = 12,0 Nm
TTFPR/L 25-200-5	5	25	25	150	22	20	200	∞	
TTFPR/L 25-250-6	6	25	25	150	22	20	250	∞	

■ Adaptéry pro modulární systém pro čelní obrábění
typ TCFR/L ...

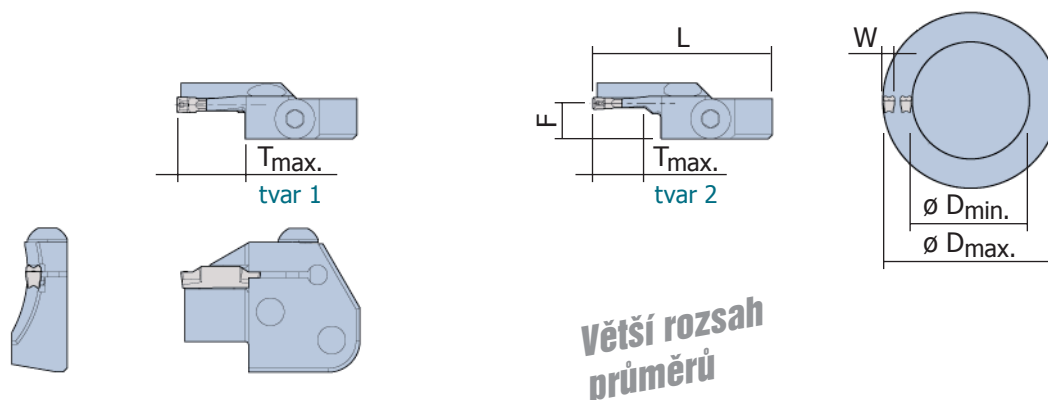

objedn. číslo	W	L	F	T _{max.}	D _{min.}	D _{max.}	tvar	upnutí
TCFR/L 3T12-40-55 RN	3	45	8,9	12	40	55		
TCFR/L 3T12-55-75 RN	3	45	8,9	12	55	75		
TCFR/L 3T12-75-100 RN	3	45	8,9	12	75	100	2	
TCFR/L 3T12-100-140 RN	3	45	8,9	12	100	140		
TCFR/L 3T12-140-200 RN	3	45	8,9	12	140	200		
TCFR/L 4T16-50-70 RN	4	45	8,5	16	50	70		
TCFR/L 4T16-70-100 RN	4	45	8,5	16	70	100		
TCFR/L 4T16-100-150 RN	4	45	8,5	16	100	150		
TCFR/L 4T16-150-250 RN	4	45	8,5	16	150	250		šroub BH M6x1x20
TCFR/L 5T20-55-80 RN	5	49	8	20	55	80		klíč L-W 4 M = 5,5 Nm
TCFR/L 5T20-80-120 RN	5	49	8	20	80	120		
TCFR/L 5T20-120-180 RN	5	49	8	20	120	180		držák TCHR/L ...
TCFR/L 5T20-180-300 RN	5	49	8	20	180	300	1	TCHPR/L ...
TCFR/L 6T25-60-90 RN	6	55	7,5	25	60	90		
TCFR/L 6T25-90-150 RN	6	55	7,5	25	90	150		
TCFR/L 6T25-150-250 RN	6	55	7,5	25	150	250		
TCFR/L 6T25-250-400 RN	6	55	7,5	25	250	400		
TCFR/L 4T16-250 RN	4	45	8,5	16	250	∞		
TCFR/L 5T20-300 RN	5	49	8	20	300	∞		
TCFR/L 6T25-400 RN	6	55	7,5	25	400	∞		

■ Držáky pro vnější obrábění
typ TTER/L ...



NOVINKA
vel. 32x32

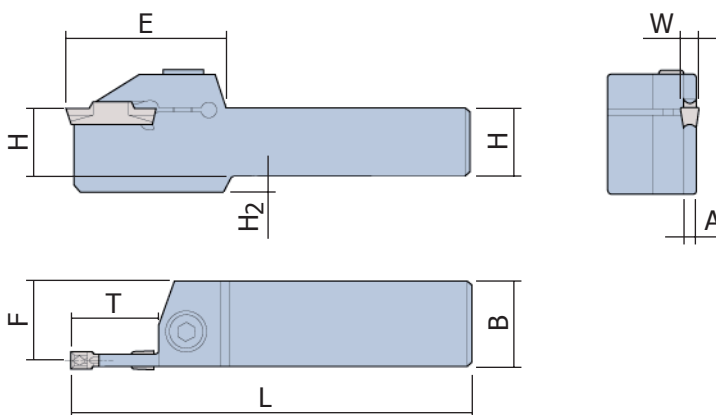

objedn. číslo	W	H	B	L	F	E	A	H ₂	T _{max.}	upnutí (šroub, klíč, ...)
TTER/L 1616-2T17	2	16	16	110	15,1	37	1,8	4	17	SH M5x0,8x16
TTER/L 2020-2T17	2	20	20	125	19,1	37	1,8	-	17	SH M5x0,8x20
TTER/L 2525-2T17	2	25	25	150	24,1	37	1,8	-	17	SH M5x0,8x25
TTER/L 1616-3T20	3	16	16	110	14,8	39	2,4	4	20	SH M5x0,8x16
TTER/L 2020-3T20	3	20	20	125	18,8	39	2,4	-	20	SH M5x0,8x20
TTER/L 2525-3T20	3	25	25	150	23,8	39	2,4	-	20	SH M5x0,8x25
TTER/L 2525-3T25	3	25	25	150	23,8	39	2,4	-	25	SH M5x0,8x25
TTER/L 1616-4T25	4	16	16	110	14,5	45	3,0	4	25	SH M6x1x16
TTER/L 2020-4T25	4	20	20	125	18,5	45	3,0	-	25	SH M6x1x20
TTER/L 2525-4T25	4	25	25	150	23,5	45	3,0	-	25	SH M6x1x25
TTER/L 2525-5T32	5	25	25	150	23,0	56	4,0	-	32	SH M6x1x25
TTER/L 2525-6T32	6	25	25	150	22,5	56	5,0	7	32	SH M6x1x25
TTER/L 2525-8T36	8	25	25	150	22,1	42	6,0	7	32	SH M8x1,25x25
TTER/L 3232-5T20	5	32	32	170	30,0	39	4,0	-	20	SH M6x1x25
TTER/L 3232-5T32	5	32	32	170	30,0	56	4,0	-	32	SH M6x1x25
TTER/L 3232-6T20	6	32	32	170	29,5	39	5,0	-	20	SH M6x1x25
TTER/L 3232-6T32	6	32	32	170	29,5	56	5,0	-	32	SH M6x1x25
TTER/L 3232-8T36	8	32	32	170	29,1	60	6,0	-	32	SH M8x1,25x25

klíč L-W 4
M = 5,5 Nm

klíč L-W 5
M = 8,0 Nm

■ **Zesílené držáky pro vnější obrábění**
typ TTER/L ...

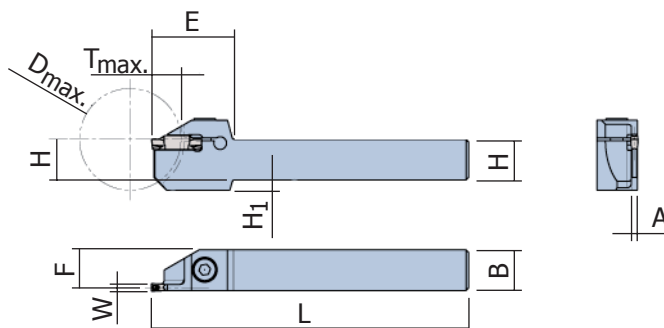

objedn. číslo	W	H	B	L	F	E	H ₁	A	T _{max.}	D _{max.}	upnutí (šroub, klíč, ...)
TTER/L 1010-1.4T15-D40	1	10	10	125	9,5	32	6	1,0	15	40	SH M5x0,8x16
TTER/L 1212-1.4T15-D40	1	12	12	125	11,5	32	4	1,0	15	40	SH M5x0,8x16
TTER/L 1616-1.4T20-D45	1	16	16	125	15,5	38	4	1,0	20	45	SH M5x0,8x20
TTER/L 2020-1.4T20-D45	1	20	20	125	19,5	38	-	1,0	20	45	SH M5x0,8x20
TTER/L 1010-2T15-D40	2	10	10	125	9,1	32	6	1,8	15	40	SH M5x0,8x16
TTER/L 1212-2T15-D40	2	12	12	125	11,1	32	4	1,8	15	40	SH M5x0,8x16
TTER/L 1616-2T20-D45	2	16	16	125	15,1	38	4	1,8	20	45	SH M5x0,8x20
TTER/L 2020-2T20-D45	2	20	20	125	19,1	38	-	1,8	20	45	SH M5x0,8x20
TTER/L 2525-2T20-D45	2	25	25	150	24,1	38	-	1,8	20	45	SH M5x0,8x25
TTER/L 1212-3T15-D40	3	12	12	125	10,8	32	4	2,4	15	40	SH M5x0,8x16
TTER/L 1616-3T20-D45	3	16	16	125	14,8	38	4	2,4	20	45	SH M5x0,8x20
TTER/L 2020-3T20-D45	3	20	20	125	18,8	38	-	2,4	20	45	SH M5x0,8x20
TTER/L 2525-3T20-D45	3	25	25	150	23,8	38	-	2,4	20	45	SH M5x0,8x25
TTER/L 2525-3T25-D60	3	25	25	150	23,8	43	-	2,4	25	60	SH M5x0,8x25

klíč L-W 4
M = 5,5 Nm

STANOVENÍ ØD OBROBKU	T _{max.}																		
	...	9	10	11	12	13	14	15	16	17	18	19	20	21	22	23	24	25	
TTER/L 1010-1.4T15-D40	ØD	∞	269	120	79	59	40												
TTER/L 1212-1.4T15-D40		∞	269	120	79	59	40												
TTER/L 1616-1.4T15-D45		∞				432	193	125	94	76	64	57	45						
TTER/L 2020-1.4T15-D45		∞				432	193	125	94	76	64	57	45						
TTER/L 1010-2T15-D40		∞	269	120	79	59	40												
TTER/L 1212-2T15-D40		∞	269	120	79	59	40												
TTER/L 1616-2T20-D45		∞				432	193	125	94	76	64	57	45						
TTER/L 2020-2T20-D45		∞				432	193	125	94	76	64	57	45						
TTER/L 2525-2T20-D45			1468	339	193	136	106	87	75	67	60	56	52	45					
TTER/L 1212-3T15-D40		∞	269	120	79	59	40												
TTER/L 1616-3T20-D45		∞				432	193	125	94	76	64	57	45						
TTER/L 2020-3T20-D45		∞				432	193	125	94	76	64	57	45						
TTER/L 2525-3T20-D45			1468	339	193	136	106	87	75	67	60	56	52	45					
TTER/L 2020-3T25-D60		∞								1810	418	237	167	130	107	91	81	73	60

■ Držáky pro vnitřní obrábění
typ TTIR/L ...



Prodloužená
hl. řezu

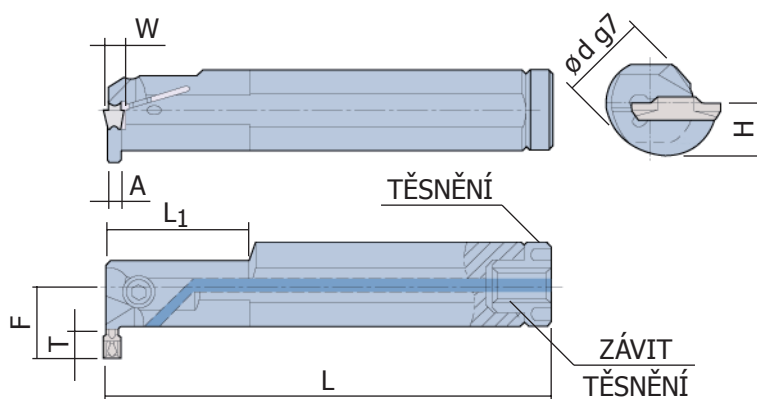

objedn. číslo	W	ød	L	L ₁	F	H	A	T _{max.}	D _{min.}	těsnění, závit	upnutí (šroub, klíč, ...)
TTIR/L 16-2C	2	16	125	-	16,5	7,5	1,8	8,5	25	PL 16 M6	SH M5x0.8x10
TTIR/L 20-2C	2	20	160	40	15,8	9	1,6	6,0	25	PL 20 M6	SH M5x0.8x12
TTIR/L 25-2C	2	25	200	40	17,5	11,5	1,6	5,0	25	PL 25 R1/8	SH M5x0.8x16
TTIR/L 20-3C	3	20	160	40	15,8	9	2,1	6,0	25	PL 20 M6	SH M5x0.8x12
TTIR/L 25-3C	3	25	200	40	17,5	11,5	2,1	5,1	25	PL 25 R1/8	SH M5x0.8x16
TTIR/L 32-3C	3	32	250	60	19,8	14	2,1	4,7	31	PL 32 R1/8	SH M5x0.8x16
TTIR/L 20-4C	4	20	160	40	15,8	9	2,9	6,0	25	PL 20 M6	SH M5x0.8x12
TTIR/L 25-4C	4	25	200	40	17,5	11,5	2,9	5,2	25	PL 25 R1/8	SH M5x0.8x16
TTIR/L 32-4C	4	32	250	60	20,8	14	2,9	4,7	31	PL 32 R1/8	SH M5x0.8x16
TTIR/L 25-5C	5	25	200	40	17,3	11,5	3,9	5,2	31	PL 25 R1/8	SH M6x1x16
TTIR/L 32-5C	5	32	250	60	20,8	14	3,9	4,7	31	PL 32 R1/8	SH M6x1x20
TTIR/L 32-6C	6	32	250	60	20,8	14	4,9	4,7	31	PL 32 R1/8	SH M6x1x20
TTIR/L 32-8C	8	32	250	60	21,3	14,5	5,9	5,5	37	PL 32 R1/8	SH M6x1x25
TTIR/L 40-8C	8	40	300	65	25,8	19	5,9	5,8	42	PL 40 R1/8	SH M6x1x25
TTIR/L 25-3C-T8	3	25	200	40	21,5	11,5	2,4	8	32	PL 25 R1/8	SH M5x0.8x16
TTIR/L 32-3C-T10	3	32	250	60	27	15	2,4	10	40	PL 32 R1/8	SH M5x0.8x20
TTIR/L 40-3C-T12	3	40	300	65	33	19	2,4	12	50	PL 40 R1/8	SH M5x0.8x25
TTIR/L 25-4C-T8	4	25	200	40	21,5	11,5	3,0	8	32	PL 25 R1/8	SH M5x0.8x16
TTIR/L 32-4C-T10	4	32	250	60	27	15	3,0	10	40	PL 32 R1/8	SH M5x0.8x20
TTIR/L 40-4C-T12	4	40	300	65	33	19	3,0	12	50	PL 40 R1/8	SH M5x0.8x25
TTIR/L 50-4C-T14	4	50	350	70	40	23,5	3,0	14	60	- -	SH M5x0.8x25
TTIR/L 32-5C-T10	5	32	250	60	27	15	3,85	10	40	PL 32 R1/8	SH M6x1x20
TTIR/L 40-5C-T12	5	40	300	65	33	19	3,85	12	50	PL 40 R1/8	SH M6x2x25
TTIR/L 50-5C-T14	5	50	350	70	40	23,5	3,85	14	60	- -	SH M6x1x25
TTIR/L 32-6C-T10	6	32	250	60	27	15	4,85	10	40	PL 32 R1/8	SH M6x1x20
TTIR/L 40-6C-T12	6	40	300	65	33	19	4,85	12	50	PL 40 R1/8	SH M6x1x25
TTIR/L 50-6C-T14	6	50	350	70	40	23,5	4,85	14	60	- -	SH M6x1x25

klíč
L-W 4
moment
5,5 Nm

klíč
L-W 5
moment
8,0 Nm

klíč
L-W 4
moment
5,5 Nm

klíč
L-W 5
moment
8,0 Nm